

Monolithic Quad SPST, CMOS Analog Switches

The DG411 series monolithic CMOS analog switches are drop-in replacements for the popular DG211 and DG212 series devices. They include four independent single pole throw (SPST) analog switches, and TTL and CMOS compatible digital inputs.

These switches feature lower analog ON resistance (<35Ω) and faster switch time ($t_{ON} < 175\text{ns}$) compared to the DG211 or DG212. Charge injection has been reduced, simplifying sample and hold applications.

The improvements in the DG411 series are made possible by using a high voltage silicon-gate process. An epitaxial layer prevents the latch-up associated with older CMOS technologies. The 44V maximum voltage range permits controlling 40V_{p-p} signals. Power supplies may be single-ended from +5V to +34V, or split from ±5V to ±20V.

The four switches are bilateral, equally matched for AC or bidirectional signals. The ON resistance variation with analog signals is quite low over a ±15V analog input range. The switches in the DG411 and DG412 are identical, differing only in the polarity of the selection logic. Two of the switches in the DG413 (#1 and #4) use the logic of the DG211 and DG411 (i.e., a logic "0" turns the switch ON) and the other two switches use DG212 and DG412 positive logic. This permits independent control of turn-on and turn-off times for SPDT configurations, permitting "break-before-make" or "make-before-break" operation with a minimum of external logic.

Features

- ON Resistance (Max) 35Ω
- Low Power Consumption (P_D) <35μW
- Fast Switching Action
 - t_{ON} (Max) 175ns
 - t_{OFF} (Max) 145ns
- Low Charge Injection
- Upgrade from DG211/DG212
- TTL, CMOS Compatible
- Single or Split Supply Operation
- Pb-Free Plus Anneal Available (RoHS Compliant)

Applications

- Audio Switching
- Battery Operated Systems
- Data Acquisition
- Hi-Rel Systems
- Sample and Hold Circuits
- Communication Systems
- Automatic Test Equipment

Ordering Information

PART NUMBER	PART MARKING	TEMP. RANGE (°C)	PACKAGE	PKG. DWG. #
DG411DJ	DG411DJ	-40 to 85	16 Ld PDIP	E16.3
DG411DJZ (Note)	DG411DJZ	-40 to 85	16 Ld PDIP** (Pb-free)	E16.3
DG411DY*	DG411DY	-40 to 85	16 Ld SOIC	M16.15
DG411DYZ* (Note)	DG411DYZ	-40 to 85	16 Ld SOIC (Pb-free)	M16.15
DG411DVZ (Note)	DG411DVZ	-40 to 85	16 Ld TSSOP (Pb-free)	M16.173
DG412DJ	DG412DJ	-40 to 85	16 Ld PDIP	E16.3
DG412DJZ (Note)	DG412DJZ	-40 to 85	16 Ld PDIP** (Pb-free)	E16.3
DG412DY*	DG412DY	-40 to 85	16 Ld SOIC	M16.15
DG412DYZ* (Note)	DG412DYZ	-40 to 85	16 Ld SOIC (Pb-free)	M16.15
DG412DVZ (Note)	DG412DVZ	-40 to 85	16 Ld TSSOP (Pb-free)	M16.173
DG413DJ	DG413DJ	-40 to 85	16 Ld PDIP	E16.3
DG413DJZ (Note)	DG413DJZ	-40 to 85	16 Ld PDIP** (Pb-free)	E16.3
DG413DY*	DG413DY	-40 to 85	16 Ld SOIC	M16.15
DG413DYZ* (Note)	DG413DYZ	-40 to 85	16 Ld SOIC (Pb-free)	M16.15
DG413DVZ (Note)	DG413DVZ	-40 to 85	16 Ld TSSOP (Pb-free)	M16.173

*Add "-T" suffix for tape and reel.

**Pb-free PDIPs can be used for through hole wave solder processing only. They are not intended for use in Reflow solder processing applications.

NOTE: Intersil Pb-free plus anneal products employ special Pb-free material sets; molding compounds/die attach materials and 100% matte tin plate termination finish, which are RoHS compliant and compatible with both SnPb and Pb-free soldering operations. Intersil Pb-free products are MSL classified at Pb-free peak reflow temperatures that meet or exceed the Pb-free requirements of IPC/JEDEC J STD-020.

TRUTH TABLE

LOGIC	DG411	DG412	DG413	
	SWITCH	SWITCH	SWITCH 1, 4	SWITCH 2, 3
0	On	Off	Off	On
1	Off	On	On	Off

NOTE: Logic "0" ≤ 0.8V. Logic "1" ≥ 2.4V.

Pinout

DG411, DG412, DG413 (PDIP, SOIC, TSSOP)
TOP VIEW

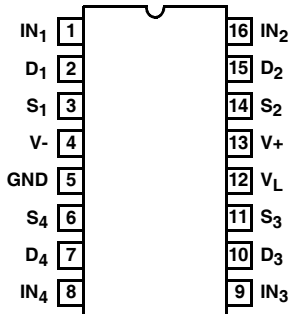

Pin Descriptions

PIN	SYMBOL	DESCRIPTION
1	IN ₁	Logic Control for Switch 1.
2	D ₁	Drain (Output) Terminal for Switch 1.
3	S ₁	Source (Input) Terminal for Switch 1.
4	V-	Negative Power Supply Terminal.
5	GND	Ground Terminal (Logic Common).
6	S ₄	Source (Input) Terminal for Switch 4.
7	D ₄	Drain (Output) Terminal for Switch 4.
8	IN ₄	Logic Control for Switch 4.
9	IN ₃	Logic Control for Switch 3.
10	D ₃	Drain (Output) Terminal for Switch 3.
11	S ₃	Source (Input) Terminal for Switch 3.
12	V _L	Logic Reference Voltage.
13	V+	Positive Power Supply Terminal (Substrate).
14	S ₂	Source (Input) Terminal for Switch 2.
15	D ₂	Drain (Output) Terminal for Switch 2.
16	IN ₂	Logic Control for Switch 2.

Functional Diagrams Four SPST Switches per Package Switches Shown for Logic "1" Input

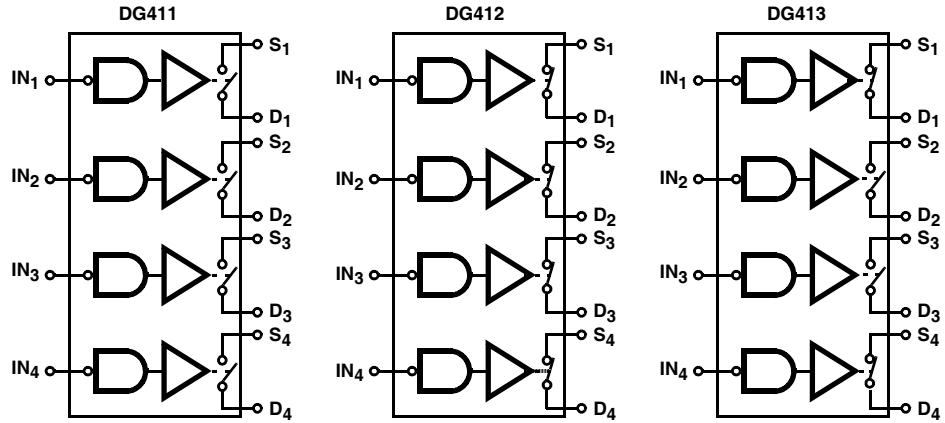

Schematic Diagram (1 Channel)

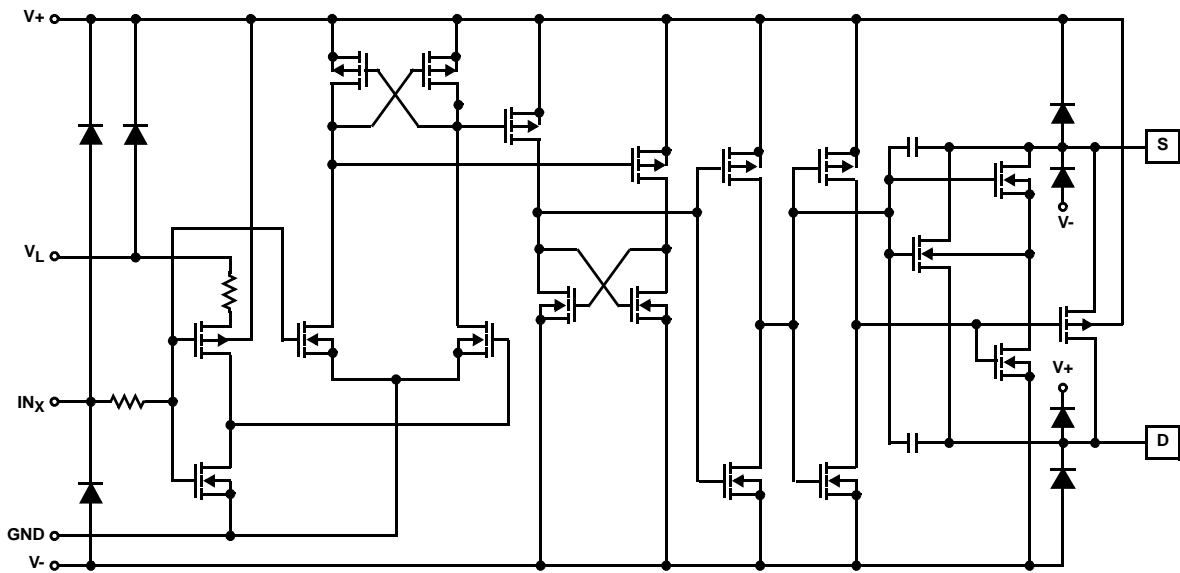

DG411, DG412, DG413

Absolute Maximum Ratings

V+ to V-	44V
GND to V-	25V
V _L	(GND -0.3V) to (V+) +0.3V
Digital Inputs, V _S , V _D (Note 1)	(V-) -2V to (V+) + 2V or 30mA, Whichever Occurs First
Continuous Current (Any Terminal)	30mA
Peak Current, S or D (Pulsed 1ms, 10% Duty Cycle Max)	100mA

Operating Conditions

Voltage Range	±20V (Max)
Temperature Range	-40°C to 85°C
Input Low Voltage	0.8V (Max)
Input High Voltage	2.4V (Min)
Input Rise and Fall Time	≤20ns

CAUTION: Stresses above those listed in "Absolute Maximum Ratings" may cause permanent damage to the device. This is a stress only rating and operation of the device at these or any other conditions above those indicated in the operational sections of this specification is not implied.

NOTES:

1. Signals on S_X, D_X, or IN_X exceeding V+ or V- will be clamped by internal diodes. Limit forward diode current to maximum current ratings.
2. θ_{JA} is measured with the component mounted on a low effective thermal conductivity test board in free air. See Tech Brief TB379 for details.

Thermal Information

Thermal Resistance (Typical, Note 2)	θ _{JA} (°C/W)
PDIP Package*	90
SOIC Package	110
TSSOP Package	150
Maximum Junction Temperature (Plastic Packages)	150°C
Maximum Storage Temperature Range	-65°C to 150°C
Maximum Lead Temperature (Soldering 10s)	300°C (SOIC and TSSOP - Lead Tips Only)

*Pb-free PDIPs can be used for through hole wave solder processing only. They are not intended for use in Reflow solder processing applications.

Electrical Specifications Test Conditions: V+ = +15V, V- = -15V, V_L = 5V, V_{IN} = 2.4V, 0.8V (Note 3), Unless Otherwise Specified

PARAMETER	TEST CONDITIONS	TEMP (°C)	(NOTE 4) MIN	(NOTE 5) TYP	(NOTE 4) MAX	UNITS
DYNAMIC CHARACTERISTICS						
Turn-ON Time, t _{ON}	R _L = 300Ω, C _L = 35pF, V _S = ±10V (Figure 1)	25	-	110	175	ns
		85	-	-	220	ns
Turn-OFF Time, t _{OFF}		25	-	100	145	ns
		85	-	-	160	ns
Break-Before-Make Time Delay	DG413 Only, R _L = 300Ω, C _L = 35pF (Figure 2)	25	-	25	-	ns
Charge Injection, Q (Figure 3)	C _L = 10nF, V _G = 0V, R _G = 0Ω	25	-	5	-	pC
OFF Isolation (Figure 5)	R _L = 50Ω, C _L = 5pF, f = 1MHz	25	-	68	-	dB
		25	-	-85	-	dB
Source OFF Capacitance, C _{S(OFF)}	f = 1MHz (Figure 6)	25	-	9	-	pF
Drain OFF Capacitance, C _{D(OFF)}		25	-	9	-	pF
Channel ON Capacitance, C _{D(ON)} + C _{S(ON)}		25	-	35	-	pF
DIGITAL INPUT CHARACTERISTICS						
Input Current V _{IN} Low, I _{IL}	V _{IN} Under Test = 0.8V, All Others = 2.4V	Full	-0.5	0.005	0.5	μA
Input Current V _{IN} High, I _{IH}	V _{IN} Under Test = 2.4V, All Others = 0.8V	Full	-0.5	0.005	0.5	μA
ANALOG SWITCH CHARACTERISTICS						
Analog Signal Range, V _{ANALOG}	I _S = ±10mA	Full	-15	-	15	V
Drain-Source ON Resistance, r _{DS(ON)}	I _S = ±10mA, V _D = ±8.5V, V+ = 13.5V, V- = -13.5V	25	-	25	35	Ω
		Full	-	-	45	Ω

DG411, DG412, DG413

Electrical Specifications Test Conditions: $V_+ = +15V$, $V_- = -15V$, $V_L = 5V$, $V_{IN} = 2.4V, 0.8V$ (Note 3),
Unless Otherwise Specified **(Continued)**

PARAMETER	TEST CONDITIONS	TEMP (°C)	(NOTE 4) MIN	(NOTE 5) TYP	(NOTE 4) MAX	UNITS
Source OFF Leakage Current, $I_{S(OFF)}$	$V_+ = 16.5V, V_- = -16.5V, V_D = \pm 15.5V, V_S = \mp 15.5V$	25	-0.25	± 0.1	0.25	nA
		Full	-5	-	+5	nA
Drain OFF Leakage Current, $I_{D(OFF)}$		25	-0.25	± 0.1	0.25	nA
		Full	-5	-	+5	nA
Channel ON Leakage Current, $I_{D(ON)} + I_{S(ON)}$	$V_+ = 16.5V, V_- = -16.5V, V_S = V_D = \pm 15.5V$	25	-0.4	± 0.1	0.4	nA
		Full	-10	-	+10	nA
POWER SUPPLY CHARACTERISTICS						
Positive Supply Current, I_+	$V_+ = 16.5V, V_- = -16.5V, V_{IN} = 0V$ or $5V$	25	-	0.0001	1	μA
		85	-	-	5	μA
Negative Supply Current, I_-		25	-1	-0.0001	-	μA
		85	-5	-	-	μA
Logic Supply Current, I_L		25	-	0.0001	1	μA
		85	-	-	5	μA
Ground Current, I_{GND}		25	-1	-0.0001	-	μA
		85	-5	-	-	μA

Electrical Specifications (Single Supply) Test Conditions: $V_+ = +12V$, $V_- = 0V$, $V_L = 5V$, $V_{IN} = 2.4V, 0.8V$ (Note 3),
Unless Otherwise Specified

PARAMETER	TEST CONDITIONS	TEMP (°C)	(NOTE 4) MIN	(NOTE 5) TYP	(NOTE 4) MAX	UNITS
DYNAMIC CHARACTERISTICS						
Turn-ON Time, t_{ON}	$R_L = 300\Omega, C_L = 35pF, V_S = 8V$, (Figure 1)	25	-	175	250	ns
		85	-	-	315	ns
Turn-OFF Time, t_{OFF}		25	-	95	125	ns
		85	-	-	140	ns
Break-Before-Make Time Delay	DG413 Only, $R_L = 300\Omega, C_L = 35pF, V_S = 8V$	25	-	25	-	ns
Charge Injection, Q	$C_L = 10nF, V_G = 6.0V, R_G = 0\Omega$	25	-	25	-	pC
ANALOG SWITCH CHARACTERISTICS						
Analog Signal Range, V_{ANALOG}		Full	0	-	12	V
Drain-Source ON Resistance, $r_{DS(ON)}$	$I_S = -10mA, V_D = 3V, 8V, V_+ = 10.8V$	25	-	40	80	Ω
		Full	-	-	100	Ω

Electrical Specifications (Single Supply) Test Conditions: $V_+ = +12V$, $V_- = 0V$, $V_L = 5V$, $V_{IN} = 2.4V, 0.8V$ (Note 3), Unless Otherwise Specified **(Continued)**

PARAMETER	TEST CONDITIONS	TEMP (°C)	(NOTE 4) MIN	(NOTE 5) TYP	(NOTE 4) MAX	UNITS
POWER SUPPLY CHARACTERISTICS						
Positive Supply Current, I_+	$V_+ = 13.2V$, $V_- = 0V$ $V_{IN} = 0V$ or $5V$	25	-	0.0001	1	μA
		85	-	-	5	μA
Negative Supply Current, I_-		25	-1	-0.0001	-	μA
		85	-5	-	-	μA
Logic Supply Current, I_L		25	-	0.0001	1	μA
		85	-	-	5	μA
Ground Current, I_{GND}		25	-1	-0.0001	-	μA
		85	-5	-	-	μA

NOTES:

- V_{IN} = input voltage to perform proper function.
- The algebraic convention whereby the most negative value is a minimum and the most positive a maximum, is used in this data sheet.
- Typical values are for DESIGN AID ONLY, not guaranteed nor subject to production testing.

Test Circuits and Waveforms

V_O is the steady state output with the switch on. Feedthrough via switch capacitance may result in spikes at the leading and trailing edge of the output waveform.

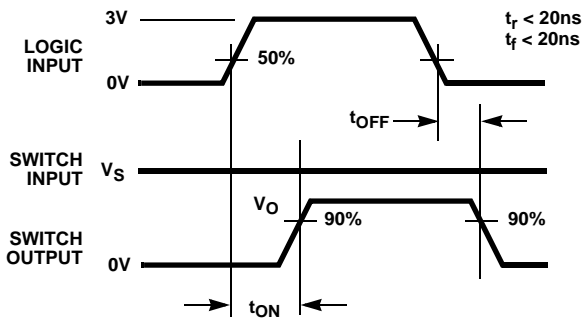
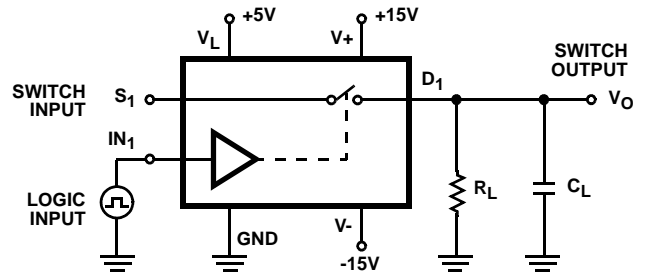

FIGURE 1A. MEASUREMENTS POINTS

FIGURE 1. SWITCHING TIMES

NOTE: Logic input waveform is inverted for switches that have the opposite logic sense.



Repeat test for all IN and S. For load conditions, see Specifications. C_L includes fixture and stray capacitance.

$$V_O = V_S \frac{R_L}{R_L + r_{DS(ON)}}$$

FIGURE 1B. TEST CIRCUIT

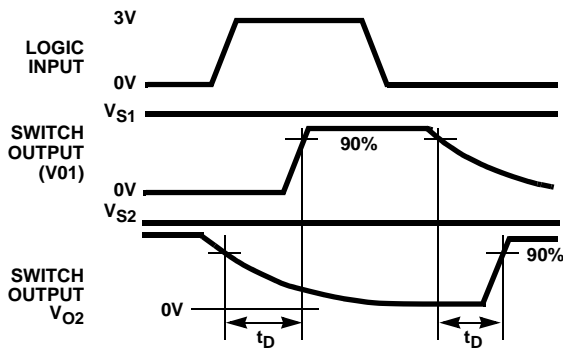

FIGURE 2A. MEASUREMENT POINTS

FIGURE 2. BREAK-BEFORE-MAKE TIME

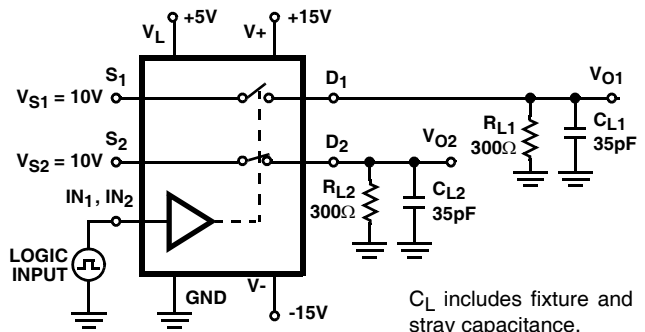

FIGURE 2B. TEST CIRCUITS

C_L includes fixture and stray capacitance.

Test Circuits and Waveforms (Continued)

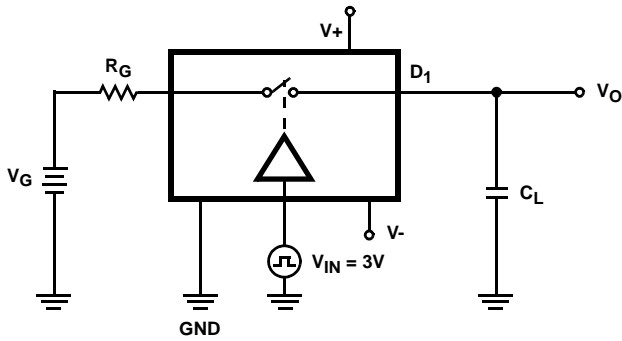
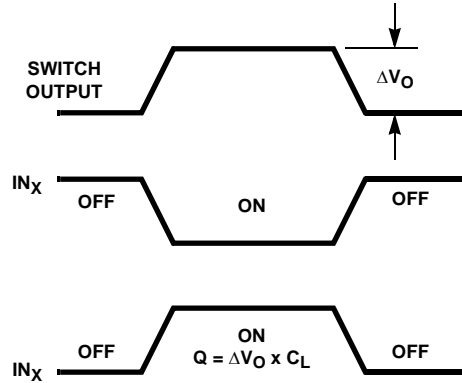

FIGURE 3A. TEST CIRCUIT



NOTE: IN_X dependent on switch configuration, input polarity determined by sense of switch.

FIGURE 3B. MEASUREMENT POINTS

FIGURE 3. CHARGE INJECTION

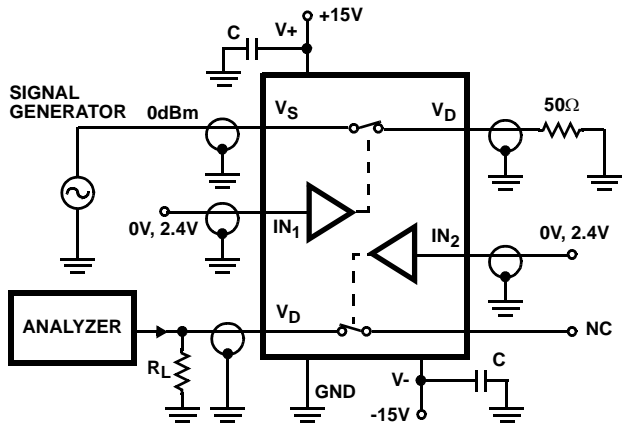

FIGURE 4. CROSTALK TEST CIRCUIT

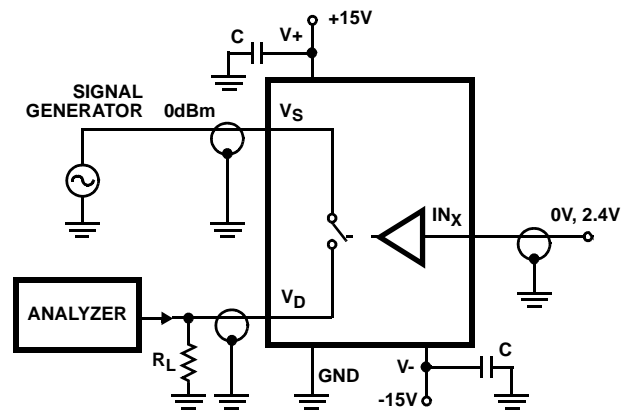

FIGURE 5. OFF ISOLATION TEST CIRCUIT

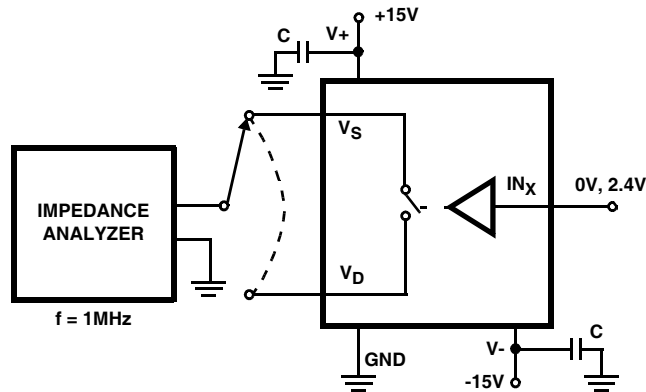

FIGURE 6. SOURCE/DRAIN CAPACITANCES TEST CIRCUIT

Application Information

Single Supply Operation

The DG411, DG412, DG413 can be operated with unipolar supplies from 5V to 44V. These devices are characterized and tested for single supply operation at 12V to facilitate the majority of applications. To function properly, 12V is tied to Pins 13 and 0V is tied to Pin 4.

Pin 12 still requires 5V for TTL compatible switching.

Summing Amplifier

When driving a high impedance, high capacitance load such as shown in Figure 7, where the inputs to the summing amplifier have some noise filtering, it is necessary to have shunt switches for rapid discharge of the filter capacitor, thus preventing offsets from occurring at the output.

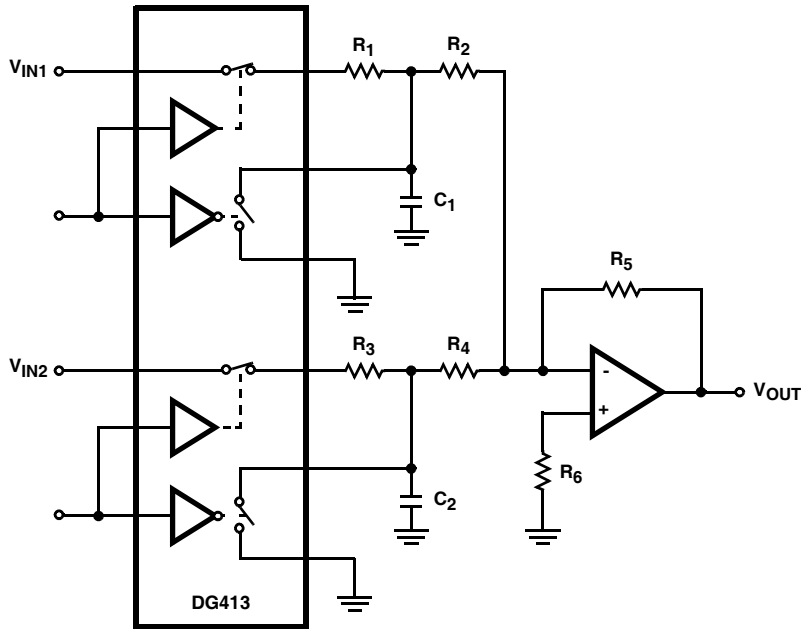

FIGURE 7. SUMMING AMPLIFIER

Typical Performance Curves

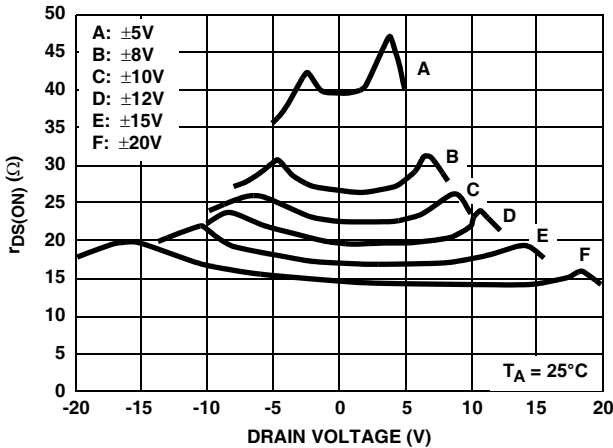

FIGURE 8. ON RESISTANCE vs V_D AND POWER SUPPLY VOLTAGE

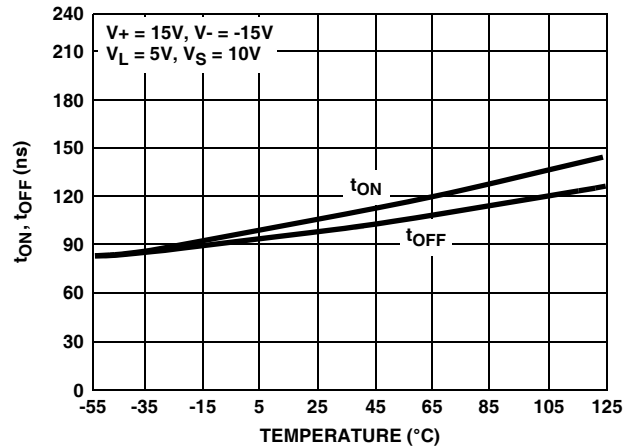

FIGURE 9. SWITCHING TIME vs TEMPERATURE

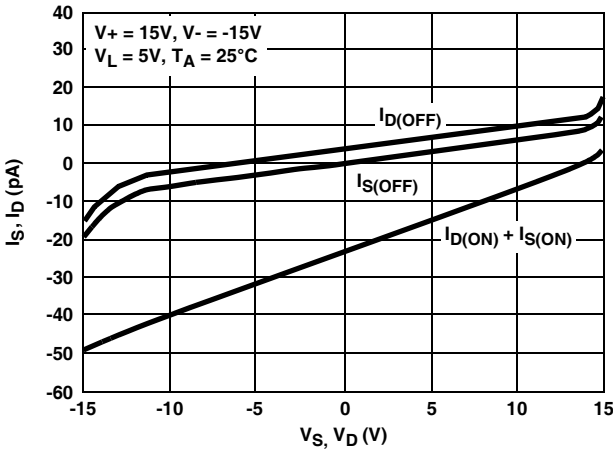

FIGURE 10. LEAKAGE CURRENTS vs ANALOG VOLTAGE

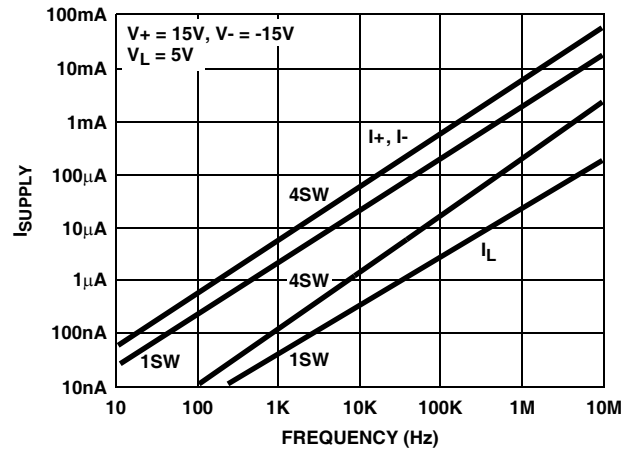

FIGURE 11. SUPPLY CURRENT vs INPUT SWITCHING FREQUENCY

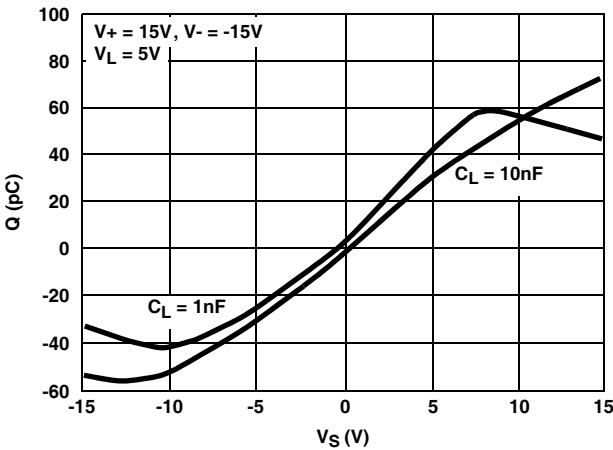

FIGURE 12. CHARGE INJECTION vs SOURCE VOLTAGE

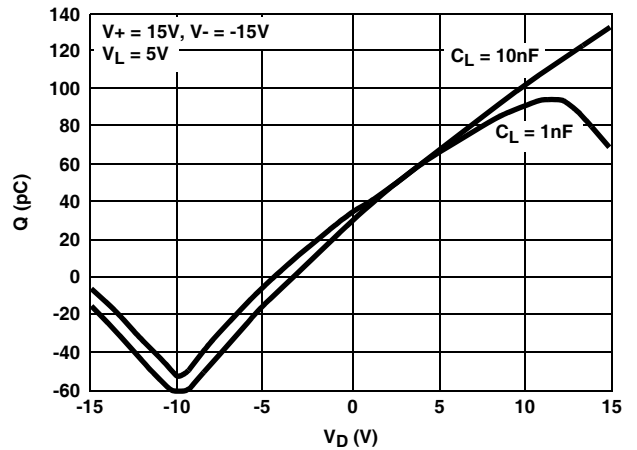

FIGURE 13. CHARGE INJECTION vs DRAIN VOLTAGE

Die Characteristics

DIE DIMENSIONS:

2760 μ m x 1780 μ m x 485 μ m

METALLIZATION:

Type: SiAl

Thickness: 12k \AA \pm 1k \AA

PASSIVATION:

Type: Nitride

Thickness: 8k \AA \pm 1k \AA

WORST CASE CURRENT DENSITY:

1.5 x 10⁵ A/cm²

Metallization Mask Layout

DG411, DG412, DG413

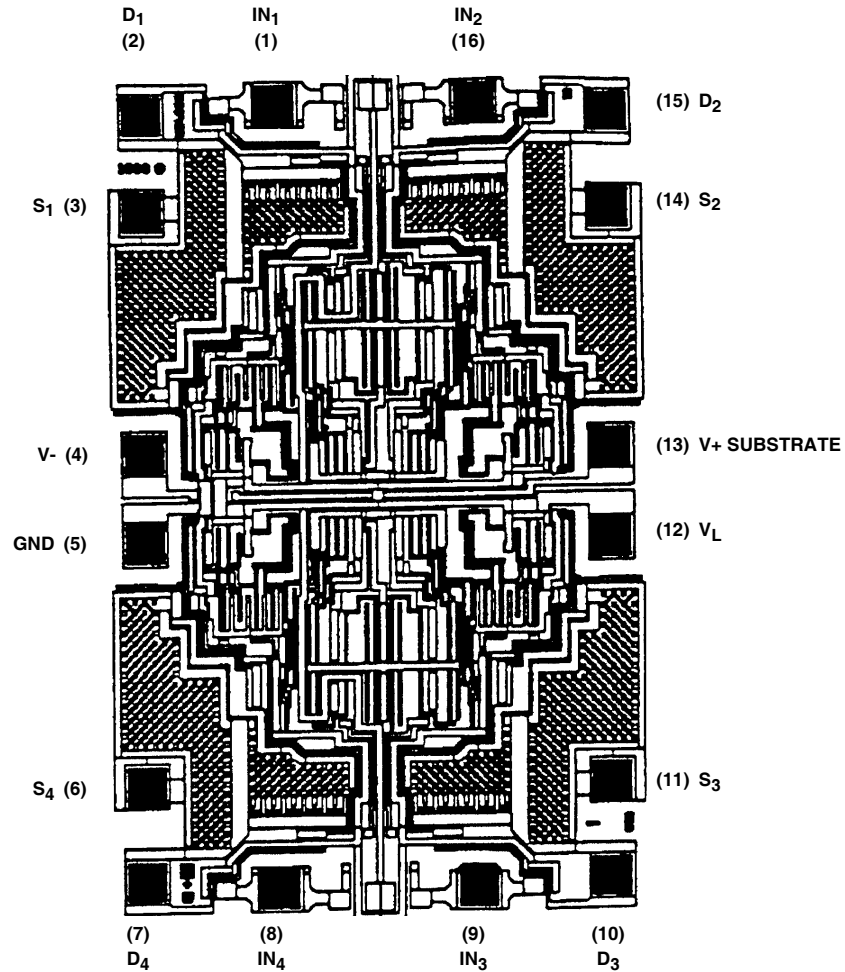

Thin Shrink Small Outline Plastic Packages (TSSOP)

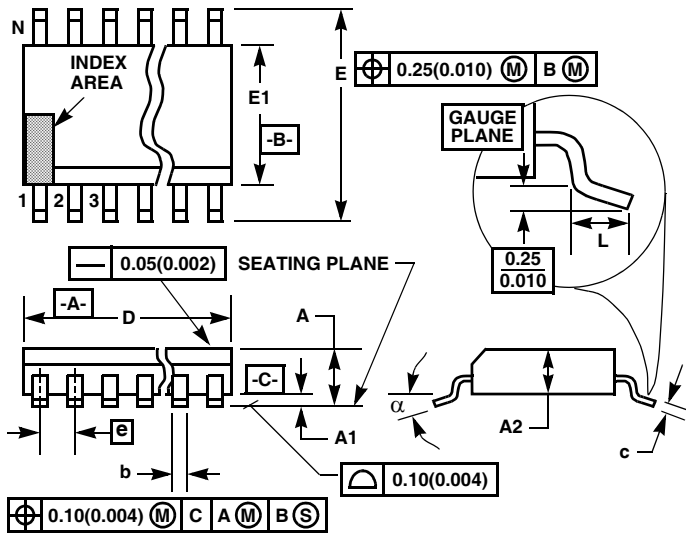

M16.173
16 LEAD THIN SHRINK SMALL OUTLINE PLASTIC PACKAGE

SYMBOL	INCHES		MILLIMETERS		NOTES
	MIN	MAX	MIN	MAX	
A	-	0.043	-	1.10	-
A1	0.002	0.006	0.05	0.15	-
A2	0.033	0.037	0.85	0.95	-
b	0.0075	0.012	0.19	0.30	9
c	0.0035	0.008	0.09	0.20	-
D	0.193	0.201	4.90	5.10	3
E1	0.169	0.177	4.30	4.50	4
e	0.026 BSC		0.65 BSC		-
E	0.246	0.256	6.25	6.50	-
L	0.020	0.028	0.50	0.70	6
N	16		16		7
α	0°	8°	0°	8°	-

NOTES:

1. These package dimensions are within allowable dimensions of JEDEC MO-153-AB, Issue E.
2. Dimensioning and tolerancing per ANSI Y14.5M-1982.
3. Dimension "D" does not include mold flash, protrusions or gate burrs. Mold flash, protrusion and gate burrs shall not exceed 0.15mm (0.006 inch) per side.
4. Dimension "E1" does not include interlead flash or protrusions. Interlead flash and protrusions shall not exceed 0.15mm (0.006 inch) per side.
5. The chamfer on the body is optional. If it is not present, a visual index feature must be located within the crosshatched area.
6. "L" is the length of terminal for soldering to a substrate.
7. "N" is the number of terminal positions.
8. Terminal numbers are shown for reference only.
9. Dimension "b" does not include dambar protrusion. Allowable dambar protrusion shall be 0.08mm (0.003 inch) total in excess of "b" dimension at maximum material condition. Minimum space between protrusion and adjacent lead is 0.07mm (0.0027 inch).
10. Controlling dimension: MILLIMETER. Converted inch dimensions are not necessarily exact. (Angles in degrees)

Rev. 1 2/02

Dual-In-Line Plastic Packages (PDIP)

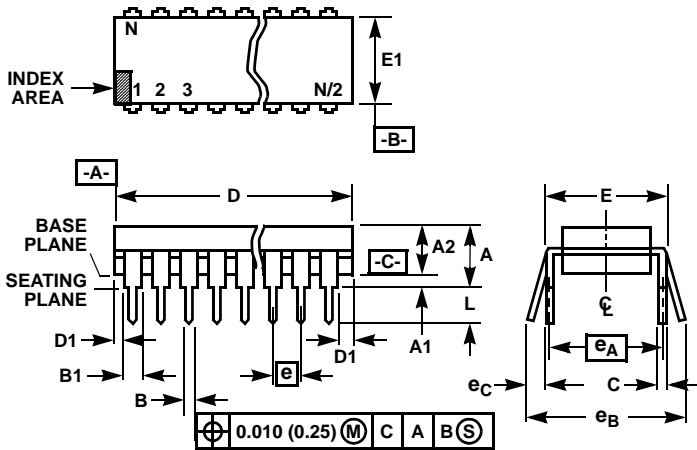

NOTES:

1. Controlling Dimensions: INCH. In case of conflict between English and Metric dimensions, the inch dimensions control.
2. Dimensioning and tolerancing per ANSI Y14.5M-1982.
3. Symbols are defined in the "MO Series Symbol List" in Section 2.2 of Publication No. 95.
4. Dimensions A, A1 and L are measured with the package seated in JEDEC seating plane gauge GS-3.
5. D, D1, and E1 dimensions do not include mold flash or protrusions. Mold flash or protrusions shall not exceed 0.010 inch (0.25mm).
6. E and e_A are measured with the leads constrained to be perpendicular to datum [-C-].
7. e_B and e_C are measured at the lead tips with the leads unconstrained. e_C must be zero or greater.
8. B1 maximum dimensions do not include dambar protrusions. Dambar protrusions shall not exceed 0.010 inch (0.25mm).
9. N is the maximum number of terminal positions.
10. Corner leads (1, N, N/2 and N/2 + 1) for E8.3, E16.3, E18.3, E28.3, E42.6 will have a B1 dimension of 0.030 - 0.045 inch (0.76 - 1.14mm).

E16.3 (JEDEC MS-001-BB ISSUE D)
16 LEAD DUAL-IN-LINE PLASTIC PACKAGE

SYMBOL	INCHES		MILLIMETERS		NOTES
	MIN	MAX	MIN	MAX	
A	-	0.210	-	5.33	4
A1	0.015	-	0.39	-	4
A2	0.115	0.195	2.93	4.95	-
B	0.014	0.022	0.356	0.558	-
B1	0.045	0.070	1.15	1.77	8, 10
C	0.008	0.014	0.204	0.355	-
D	0.735	0.775	18.66	19.68	5
D1	0.005	-	0.13	-	5
E	0.300	0.325	7.62	8.25	6
E1	0.240	0.280	6.10	7.11	5
e	0.100 BSC		2.54 BSC		-
e_A	0.300 BSC		7.62 BSC		6
e_B	-	0.430	-	10.92	7
L	0.115	0.150	2.93	3.81	4
N	16		16		9

Rev. 0 12/93

Small Outline Plastic Packages (SOIC)

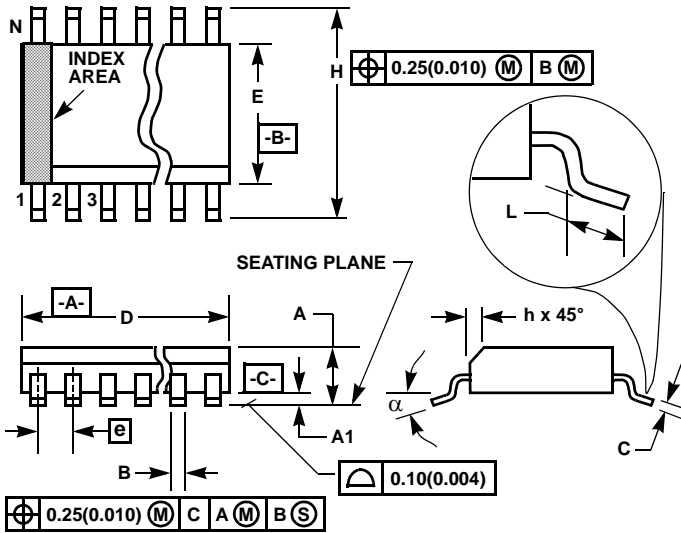

M16.15 (JEDEC MS-012-AC ISSUE C)
16 LEAD NARROW BODY SMALL OUTLINE PLASTIC PACKAGE

SYMBOL	INCHES		MILLIMETERS		NOTES
	MIN	MAX	MIN	MAX	
A	0.0532	0.0688	1.35	1.75	-
A1	0.0040	0.0098	0.10	0.25	-
B	0.013	0.020	0.33	0.51	9
C	0.0075	0.0098	0.19	0.25	-
D	0.3859	0.3937	9.80	10.00	3
E	0.1497	0.1574	3.80	4.00	4
e	0.050 BSC		1.27 BSC		-
H	0.2284	0.2440	5.80	6.20	-
h	0.0099	0.0196	0.25	0.50	5
L	0.016	0.050	0.40	1.27	6
N	16		16		7
α	0°	8°	0°	8°	-

NOTES:

1. Symbols are defined in the "MO Series Symbol List" in Section 2.2 of Publication Number 95.
2. Dimensioning and tolerancing per ANSI Y14.5M-1982.
3. Dimension "D" does not include mold flash, protrusions or gate burrs. Mold flash, protrusion and gate burrs shall not exceed 0.15mm (0.006 inch) per side.
4. Dimension "E" does not include interlead flash or protrusions. Interlead flash and protrusions shall not exceed 0.25mm (0.010 inch) per side.
5. The chamfer on the body is optional. If it is not present, a visual index feature must be located within the crosshatched area.
6. "L" is the length of terminal for soldering to a substrate.
7. "N" is the number of terminal positions.
8. Terminal numbers are shown for reference only.
9. The lead width "B", as measured 0.36mm (0.014 inch) or greater above the seating plane, shall not exceed a maximum value of 0.61mm (0.024 inch).
10. Controlling dimension: MILLIMETER. Converted inch dimensions are not necessarily exact.

Rev. 1 6/05

All Intersil U.S. products are manufactured, assembled and tested utilizing ISO9000 quality systems. Intersil Corporation's quality certifications can be viewed at www.intersil.com/design/quality

Intersil products are sold by description only. Intersil Corporation reserves the right to make changes in circuit design, software and/or specifications at any time without notice. Accordingly, the reader is cautioned to verify that data sheets are current before placing orders. Information furnished by Intersil is believed to be accurate and reliable. However, no responsibility is assumed by Intersil or its subsidiaries for its use; nor for any infringements of patents or other rights of third parties which may result from its use. No license is granted by implication or otherwise under any patent or patent rights of Intersil or its subsidiaries.

For information regarding Intersil Corporation and its products, see www.intersil.com